

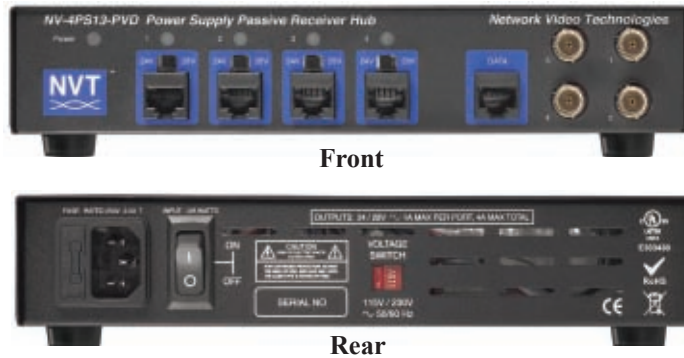

## Model NV-4PS13-PVD Power Supply Passive Receiver Hub



### Features:

- Provides Class 2 SELV camera power while receiving video transmission and delivering P/T/Z telemetry all over a single 4-pair Cat5e cable
- Standard telecom/datacom structured cabling pinouts per EIA/TIA 568B
- Independently selectable 24VAC-OFF-28VAC with 1 Amp per channel
- Automatic-reset fault protection; transient protection
- Individually floating outputs ensure total ground-loop immunity
- Diagnostic LEDs show load/no load, miswires, and overload conditions
- Use with the NV-216A-PV, NV-218A-PVD or the NV-226J-PV transceiver at the camera
- Power cameras via UTP over significant distances (see Power Distance Chart)
- 1U high x 8" deep wall, desk or desk rack-mountable
- Limited lifetime warranty

The 4-channel NV-4PS13-PVD is a key hybrid component that consolidates all CCTV system cabling using standard EIA/TIA 568B structured building wiring. Designed for installation in the IDF/Telecom Closet or MDF/Equipment Room, the Power Supply Passive Video Receiver Hub has independently selectable 24VAC-OFF-28VAC outputs that can support at-distance camera loads up to 1 Amp per channel. Use with NVT's PVD™ transceivers for cable runs under 750ft (225m). A built-in passive receiver hub allows connection to DVR or an encoder for IP transmission. Per-channel diagnostic LEDs display load /no-load, miswires, or fault conditions at a glance. Automatic-reset fault protection, transient protection, and ground loop free individually floating outputs.

### Network Video Technologies

4005 Bohannon Drive • Menlo Park, CA 94025 • USA  
(+1) 650.462.8100 • FAX (+1) 650.326.1940  
nvt.com • www.nvt.com/email



# Model NV-4PS13-PVD

## Power Supply Passive Receiver Hub

### Technical Specifications

#### WIRE DISTANCE (Power Distance Charts)

Supply voltage, wire resistance and minimum camera operating voltage determine the maximum camera distance. Examples assume a minimum 21 VAC at the 24 VAC camera

Fixed Camera 24VAC only, used with NV-216A-PV		
Power Supply Voltage	24 VAC	28 VAC
Minimum Voltage at Camera	21 VAC	21 VAC
<b>B&amp;W Camera, 2.4 W</b>		
2-pair 24 AWG	789ft (240m)	1,840ft (561m)
2-pair 23 AWG	994ft (303m)	2,320ft (707m)
<b>Color Camera, 4.8 W</b>		
2-pair 24 AWG	393ft (120m)	916ft (279m)
2-pair 23 AWG	495ft (151m)	1,155ft (352m)
<b>Color Camera, 7.2 W</b>		
2-pair 24 AWG	262ft (80m)	612ft (186m)
2-pair 23 AWG	331ft (101m)	771ft (235m)

Fixed Dual Voltage 24VAC/12VDC Camera with NV-216A-PV		
Power Supply Voltage	24 VAC	28 VAC
Minimum Voltage at Camera	14 VAC	14 VAC
<b>B&amp;W Camera, 2.4 W</b>		
2-pair 24 AWG	1,753ft (534m)	2,454ft (748m)
2-pair 23 AWG	2,210ft (674m)	3,094ft (943m)
<b>Color Camera, 4.8 W</b>		
2-pair 24 AWG	874ft (266m)	1,223ft (373m)
2-pair 23 AWG	1,102ft (336m)	1,542ft (470m)
<b>Color Camera, 7.2 W</b>		
2-pair 24 AWG	583ft (178m)	816ft (249m)
2-pair 23 AWG	735ft (224m)	1,029ft (314m)

P/T/Z 24VAC Camera used with NV-218A-PVD		
Power Supply Voltage	24 VAC	28 VAC
Minimum Voltage at Camera	21 VAC	21 VAC
<b>P/T/Z Camera, 21 W</b>		
2-pair 24 AWG	90ft (27m)	210ft (64m)
2-pair 23 AWG	113ft (35m)	265ft (81m)

Fixed 12VDC Camera used with NV-226J-PV		
Power Supply Voltage	24 VAC	28 VAC
<b>B&amp;W Camera, 2.4 W</b>		
2-pair 24 AWG	1,586ft (748m)	2,220ft (677m)
2-pair 23 AWG	1,999ft (609m)	2,799ft (853m)
<b>Color Camera 4.8 W</b>		
2-pair 24 AWG	795ft (242m)	1,113ft (339m)
2-pair 23 AWG	1,002ft (306m)	1,403ft (428m)

Notes: Actual distance will depend on the camera's inrush and operating current, minimum operating voltage, and the wire's environmental temperature. Please consult NVT Customer Support for further information.

Wire should be category rated Unshielded Twisted-Pair (UTP) cable. Low voltage camera power, video, and RS-422 or RS-485 telemetry may be sent within the same wire bundle. Do not run 24VAC or 28VAC in the same wire bundle with analog telecom signals. However you may share the same wire/cable tray.

An online wire Power Distance Calculator is available at [www.nvt.com](http://www.nvt.com) under Product Support.

#### VIDEO

Frequency response	DC to 10 MHz
Attenuation	0.5 dB typ
Common-mode / Differential-mode rejection	60 dB typ
15 KHz to 5 MHz	
Impedance	
Coax, female BNC	75 ohms
UTP, RJ45	100 ohms
Network Wiring	One four-pair Cat5 or better per channel

#### CAMERA POWER

Each camera is powered by a fully isolated (floating) Class 2 SELV output, individually switchable 24VAC / OFF/ 28VAC at up to 1 Amp. Each output is individually thermistor protected.

#### POWER INPUT

Power inlet	IEC with molded power cord (included)
On-off switch	Rear panel
Voltage	115 / 230 VAC
Current	1.25 / 0.625 Amps
Frequency	50 / 60 Hz
Protection	2.5A slo-blo 8x20mm fuse and thermal shutdown
Wattage	125 Watts
Heat	(power supply only) 50 BTU/hour (power supply with cameras) 420 BTU/hour

#### FRONT-PANEL LEDs

Blue LED	System power on
Per-channel LED indicates:	Off No load connected
Green	Load connected and working
Amber	Mis-wiring detected
Red	Overload shutdown condition

#### ENVIRONMENTAL

Ambient Temperature	-4 to 122 °F (-20 to +50 °C)
Humidity (non-condensing)	0 to 95%
Transient Immunity	per ANSI 587 C62.41

#### MECHANICAL

Dimensions	9.25in wide, 1.75in high, 7.25in deep
including connectors:	(235mm wide, 44,5mm high, 184mm deep)
Mounting	Wall, or desk mount
Product Weight	7lb (3,2kg)
Packaged Weight	8.42lb (3,8kg)

#### REGULATORY



Specifications subject to change without notice.



# Model NV-4PS13-PVD

## Power Supply Passive Receiver Hub

### CAMERA PVD CONNECTIONS

Four front-panel RJ45 outputs support up to four fixed or P/T/Z telemetry cameras over 4-pair UTP.



- 1 Video +
- 2 Video -
- 3 Data +
- 4 Power -
- 5 Power +
- 6 Data -
- 7 Power +
- 8 Power -

### CONTROL ROOM DATA

RS-422 or RS-485 type P/T/Z telemetry/ data signals are paralleled together in groups of four, and passed through the unit and delivered to the control room via a rear-panel RJ45 connector.



- 1 Video 2 +
- 2 Video 2 -
- 3 Video 3 +
- 4 Video 1 -
- 5 Video 1 +
- 6 Video 3 -
- 7 Video 4 +
- 8 Video 4 -

## Typical Application

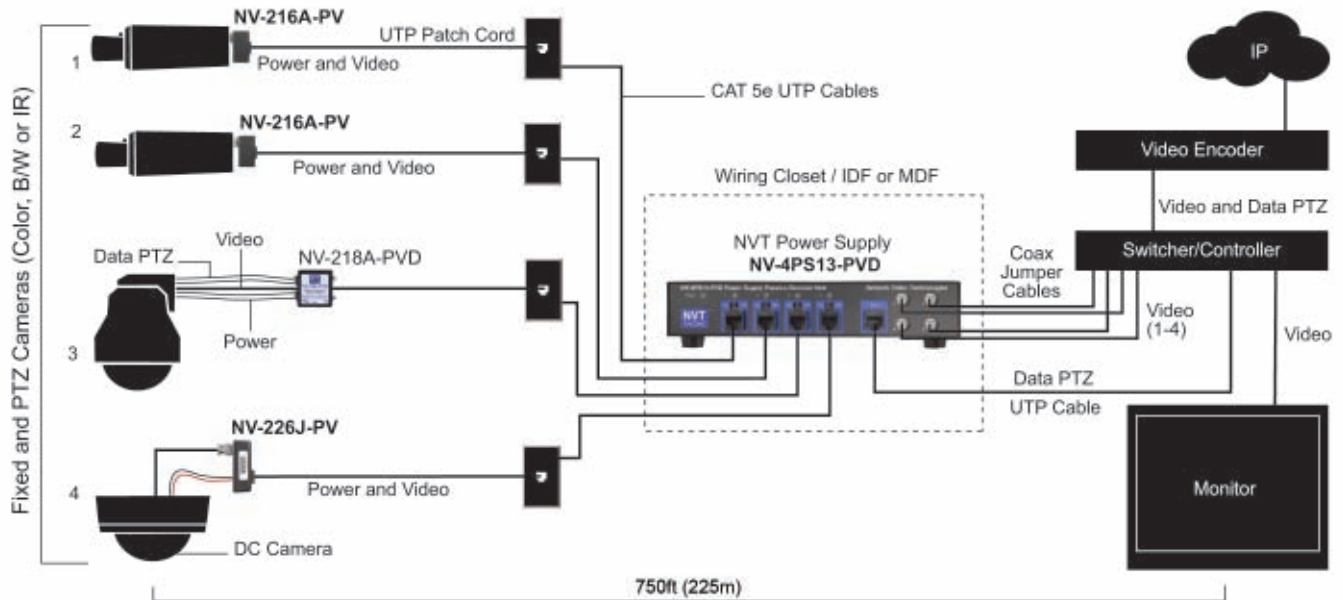

### Network Video Technologies

4005 Bohannon Drive • Menlo Park, CA 94025 • USA  
 (+1) 650.462.8100 • FAX (+1) 650.326.1940  
 nvt.com • www.nvt.com/email

Copyright © 2011 NVT, Inc.  
 410-12981-C