

Ikegami

ICD-630_(NTSC)

ICD-630P_(PAL)

High Resolution Wide Dynamic Range Vandal Resistant Dome Camera



High Resolution	High Sensitivity	High Image Quality	Varifocal Lens
700TVL	0.0007 lx / F1.2(Type31)	52dB	2.8~10mm/9~22mm

FEATURES

High Resolution Wide Dynamic Range Vandal Resistant Dome camera in an attractive and functional dome housing.



Ikegami, the world leader in high quality broadcast and professional video production equipment, is proud to announce the ICD-630/P High Resolution Wide Dynamic Range line of vandal dome cameras. The ICD-630/P operates at an impressive 700TVL and features Wide Dynamic Range functionality. The result is higher sensitivity in lower light levels (when the camera will automatically switch to a Monochrome output for improved low light performance). The built-in varifocal lens (available in two sizes) makes the ICD-620/P an excellent solution for a wide range of applications.

0.0007 lx , 700TVL High Resolution Pictures

The ICD-630/P achieves a horizontal resolution of 700 TVL with 480,000 NTSC /570,000 PAL pixels, enabling reproduction of exceptionally clear and detailed images in ultra-low light conditions. The ICD-630/P performs at levels as low as 0.0007lx / F1.2(Type 31) or 0.0017lx/f1.5(Type 92) minimum scene illumination performance (in monochrome mode)!

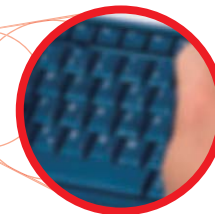

Conventional Model



ICD-630/P

52dB, High Picture Quality and Low Smear and Noise

The improved DSP circuit permits 52dB Signal-to-Noise ratio and Low Smear(-105dB). By the factor, a clear image can be captured even under strong light.



Conventional Model



ICD-630/P

Engineered Vandal Dome Camera

The low-profile ICD-620/P is designed to complement the surrounding architecture with its' smooth lines and soft curves. The vandal-resistant aluminum housing and impact-resistant dome complete the ICD-620/P package. Black color model is also available.

Focus EZ Function

A button located at the back of the ICD-630/P (inside the dome) sets the auto-iris lens aperture open, even in broad daylight. This allows the installer to set an accurate focus with the best depth of field. The EZ focus button displays an adjustment bar that makes it easy to achieve perfect focus.

Built-in Varifocal with DC Drive Iris Control

The ICD-630/P is equipped from the factory with a choice of 2.8-10mm or 9-22mm varifocal lens to cover a full range of installations.

Wide Dynamic Range (WDR)

The WDR function provides clear and high quality pictures in high contrast environments by adjusting exposure- resulting in a corrected image with clear details results. The wide dynamic range is 5 levels selectable.

Auto White Balance

The ICD-630/P features automatic tracking white balance control (ATW) and automatic white balance control (AWC). The result is better color tracking in difficult lighting conditions (such as sodium light).

High Resolution Wide Dynamic Range Vandal Resistant Dome Camera

ICD-630_(NTSC) / ICD-630P_(PAL)

SPECIFICATIONS

Image Sensor	1/3" CCD		
Effective Pixels	NTSC : Approx.480,000 pixels, Effective 976(H) x 494(V) PAL : Approx.570,000 pixels, Effective 976(H) x 582(V)		
Scanning System	NTSC : 525 lines at 59.94Hz, 2:1 interlace PAL : 625 lines at 50Hz, 2:1 interlace		
Synchronization System	Internal Crystal Lock/Line Lock		
Video Output	VBS 1.0Vp-p/75Ω		
Horizontal Resolution	700 TV Lines or better (High Resolution mode, by Rated Illumination)		
S/N Ratio	52dB or better (p-p/rms)		
Minimum Illumination	Type 31	Type 92	
	In color mode : (Electronic Sensitivity Up OFF)		
	0.22lx/F1.2[50IRE]	0.35lx/F1.5[50IRE]	
	In color mode : (Electronic Sensitivity Up ON 32x)		
	0.007lx/F1.2[50IRE]	0.017lx/F1.5[50IRE]	
	In monochrome mode : (Electronic Sensitivity Up OFF)		
	0.022lx/F1.2[25IRE]	0.035lx/F1.5[25IRE]	
Day/Night Function	Built-in, True Day/Night, Auto/Manual selectable		
	Wide Dynamic Range		
	Built-in, LOW/MIDLOW/MIDDLE/MIDHIGH/HIGH selectable		
AGC (Automatic Gain Control)	OFF/LOW/MIDLOW/MIDDLE/MIDHIGH/HIGH selectable		
Electronic Sensitivity Up	Built-in, ON (AUTO)/OFF selectable(Up to 32 times)		
White Balance	ATW(Automatic Tracking White Balance)/AWC(Automatic White Balance Control)/MANUAL selectable		
Detail Correction	Built-in (Sharpness)		
Digital Noise Reduction	Built-in, ON/OFF selectable (DNR Function)		
AES(Automatic Electronic Shutter)	Built-in		
Privacy Masking	Built-in (Maximum 15 zones)		
Flip Function	Built-in, OFF/V-FLIP/H-FLIP/HV-FLIP selectable		
Motion Detection	Built-in, ON/OFF selectable		
Digital Zoom	Built-in, ON/OFF selectable(Up to 32 times)		
Focus EZ	Built-in		
Stabilizer Function	Built-in		
Monitor Output Selection	CRT/LCD selectable		
Camera ID	Up to 52 characters (alphanumeric and symbols)		
Built-in Lens	Type 31	Type 92	
	Focal Distance	f2.8~10mm	
	Angle Adjustment(Horizontal)	28.8°~94.6°	
	Angle Adjustment(Vertical)	21.6°~68.4°	
Protection Standard	IP66 compliant		
Dome Cover	Vandal Resistance Type		
Power Requirement	NTSC : AC24V±10%, 60Hz / DC12(10.5 ~ 15V) PAL : AC24V±10%, 50Hz / DC12(10.5 ~ 15V)		
Power Consumption	ICD-630 AC24V / DC12V : 3W approx. ICD-630P DC12V / DC12V : 3W approx.		
Operating Ambient Temperature	-10°C ~+50°C(14.0°F~122°F)		
Operating Ambient Humidity	30% ~ 90% RH (non-condensing)		
External Dimensions	Ø 142.8 x H102.5mm[Ø5.62 x 4.04 inches] (without projection)		
Weight	ICD-630: 975g(3.44lbs) approx. ICD-630P: 980g(2.16lbs) approx.		
Input/ Output Connectors	Pig-tail Type VIDEO OUT -- BNC, AC24V / DC12V Input -- Open-end wire Dome Inside MON.OUT - Special connector output (Connector harness with BNC Output is available)		
Standard Accessories	Instruction Manual, MON.OUT Output Harness, Tapping screws for fixing the camera (2 pcs.)		

DIMENSIONS (Unit: mm[inch])

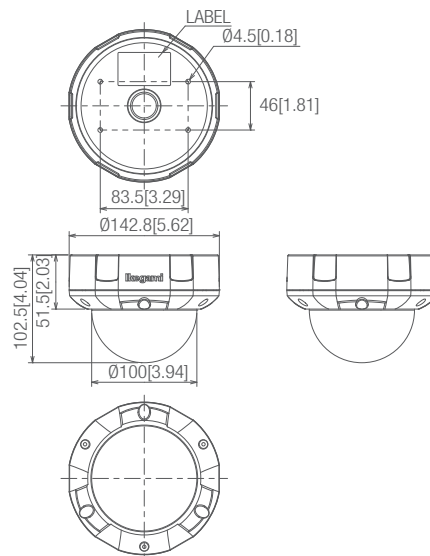

OPTIONAL ACCESSORIES

Ceiling Mount



■ XHG-3529-W(White) XHG-3529-B(Black)

Wall Mount



■ IK-DSB-PWMVCN-CG-W(White)
■ IK-DSB-PWMVCN-CG-B(Black)

Design and specifications are subject to change without notice.



U261A133-IB

Ikegami

IKEGAMI ELECTRONICS (U.S.A.), INC.

■ URL <http://www.ikegami.com>

HEADQUARTERS 37 BROOK AVENUE, MAYWOOD, NJ 07607
Phone:(201) 368-9171 Fax:(201) 569-1626

WESTCOAST OFFICE Phone:(310) 297-1900

SOUTHWEST OFFICE Phone:(972) 869-2363

MIDWEST OFFICE Phone:(708) 460-1451

SOUTHEAST OFFICE Phone:(954) 735-2203