

# High Bay

Power Selectable | Colour Selectable | 277-480V

## HB8 HIGH BAY

The successor to our best-selling HB7C High Bays!  
Ideal for warehouses, factories, gas stations, gymnasiums, grocery stores, food processing facilities, and more

Newly Designed,  
Shatterproof  
Polycarbonate Optics  
meet/exceed DLC 5.1  
glare standards



Power Selectable  
240W / 270W / 300W

Instant Start and  
0-10V Dimmable



Long Life, Elevated Driver  
for cooler operation

Colour Selectable  
3000K / 4000K / 5000K

Polyester Powder  
Coat Finish  
black

## TECHNICAL DATA



### LIGHT SPECIFICATIONS

Efficacy*	133.3 lm/W
CCT	3000K / 4000K / 5000K
CRI	82
Beam Angle	90°
Dimmable	0-10V
L70 Life	50,000 hrs
Warranty	5-year
Factory Settings	300W   4000K   90°

\*Shown at 300W and 3000K

	3000K	4000K	5000K
<b>240W</b>	32425 lm	35134 lm	34692 lm
<b>270W</b>	34039 lm	38678 lm	42259 lm
<b>300W</b>	39459 lm	46362 lm	45091 lm

### APPROVALS & LISTINGS

cUL	E482965
DLC Premium	S-L9FXMA

### DIMENSIONS AND WEIGHTS

Fixture Weight	8.9 lbs
Fixture Dimensions	15.4 x 15.4 x 8.8 in
Carton Qty	1
Carton Weight	10.8 lbs
Carton Dimensions	17.7 x 17.7 x 7.9 in

### DIMENSIONAL DRAWINGS

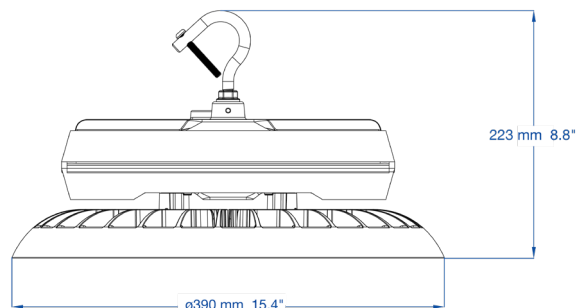

### ELECTRICAL

Wattage	240W / 270W / 300W
Voltage	277-480V
Current	1.90A
Surge Protection	6kV
Auxiliary Output	12V
Power Factor	0.9
THD	15%
Operating Temp	-40 to 50°C

### CONSTRUCTION

Power Cord	65"
Housing	Die-Cast Aluminum
Lens	Polycarbonate
Finish	Powder Coated
Finish Colour	Black
IP Rating	IP65

### ACCESSORIES (Ordered Separately)

Polycarbonate Reflector	HB8-PC-REF-XL
Polycarbonate Cover	HB8-PC-REF-XL-BCV
Aluminum Reflector	HB8-AL-REF-XL
Wire Guard	HB8-WG-XL
Yoke Mount	HB8-YK-XL
Microwave Sensor	MS04-MW-TW-DC
Infrared Motion Sensor	MS01-PIR-TW-DC
Motion Sensor Remote	MS04-RC
Frosted Lens	HB8-FR-LENS-XL
120° Optics	HB8-120D-LENS-XL
60° Optics	HB8-60D-LENS-XL
Eye Bolt	HB8-EB

NOTE: **HB01R** is **required** for the **HB01DMS-A** and **MS01-PIR-TW-DC** to function